

SELF-CLINCHING STUDS AND PINS

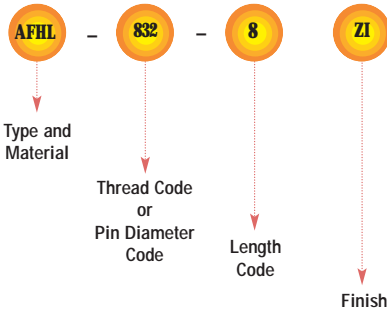

TYPE AFHL AFHLS

Part Number Designation



Installs closer to the edge of a sheet than standard studs without causing that edge to bulge.
Flush-head for sheet thickness .040" / 1 mm and greater.

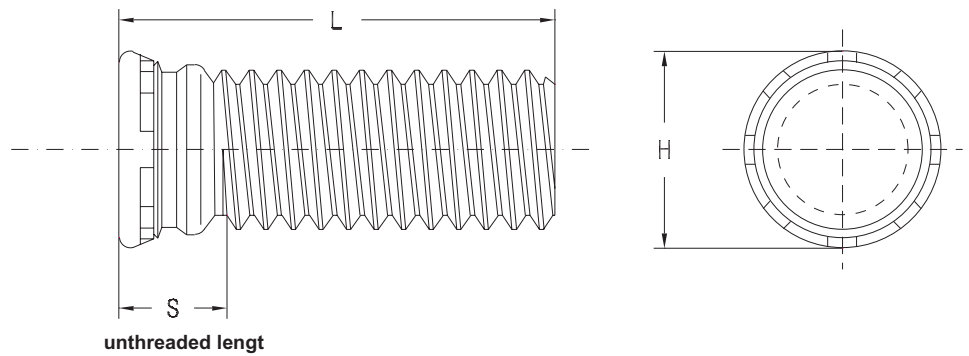

UNIFIED (inch)	Thread Size	Type		Thread Code	Length Code "L" ±.015 (Length Code in 16ths of an inch)									Min. Sheet Thickness	Hole Size in Sheet +.003 -.000	Max. Hole in Attach. Parts	H ±.015	S Max.	Min. Dist. Hole C/L to Edge
		Steel	Stainless Steel		.250	.312	.375	.500	.625	.750	.875	1.00	1.25						
	.086-56 (#2-56)	AFHL	AFHLS	256	4	5	6	8	10	12	NA	NA	NA	NA	.040	.085	.100	.112	.080
.112-40 (#4-40)	AFHL	AFHLS	440	4	5	6	8	10	12	14	16	NA	NA	.040	.111	.125	.138	.085	.124
.138-32 (#6-32)	AFHL	AFHLS	632	4	5	6	8	10	12	14	16	20	24	.040	.137	.150	.164	.090	.150
.164-32 (#8-32)	AFHL	AFHLS	832	4	5	6	8	10	12	14	16	20	24	.040	.163	.180	.190	.090	.176
.190-32 (#10-32)	AFHL	AFHLS	032	NA	5	6	8	10	12	14	16	20	24	.040	.189	.205	.225	.100	.210

METRIC (mm)	Thread Size x Pitch	Type		Thread Code	Length Code "L" ±0.4 (Length Code in millimeters)									Min. Sheet Thickness	Hole Size in Sheet +0.08	Max. Hole in Attach. Parts	H ±0.4	S Max.	Min. Dist. Hole C/L to Edge
		Steel	Stainless Steel		6	8	10	12	15	18	20	25	30						
	M2.5x0.45	AFHL	AFHLS	M2.5	6	8	10	12	15	18	NA	NA	NA	NA	1	2.5	2.9	3.15	2.1
M3x0.5	AFHL	AFHLS	M3	6	8	10	12	15	18	20	25	NA	NA	1	3	3.4	3.65	2.1	3.3
M3.5x0.6	AFHL	AFHLS	M3.5	6	8	10	12	15	18	20	25	30	NA	1	3.5	3.9	4.15	2.3	3.8
M4x0.7	AFHL	AFHLS	M4	6	8	10	12	15	18	20	25	30	35	1	4	4.4	4.65	2.4	4.3
M5x0.8	AFHL	AFHLS	M5	NA	8	10	12	15	18	20	25	30	35	1	5	5.4	5.9	2.7	5.6

NA Not Available.

SELF-CLINCHING STUDS AND PINS



MATERIAL & FINISH SPECIFICATIONS

Type	Threads*	Fastener Materials					Standard Finishes			Optional Finish	For use in Sheet Hardness:					
	External, ANSI B1.1, 2A ANSI/ASME B1.13M, 6g	Heat-Treated Carbon Steel	300 Series Stainless Steel	2024-T4 Aluminum (Plain Finish)	CDA #510 Phosphor Bronze (1)	400 Series Stainless Steel	No Finish (2) (3)	Zinc Per ASTM B 633 SC1 (5µm), Type III, Colorless	Passivated and/or Tested Per ASTM A380	Zinc Per ASTM B 633 SC1 (5µm), Type II, Yellow	50 or less on the Rockwell "B" Scale	55 or less on the Rockwell "B" Scale	70 or less on the Rockwell "B" Scale	80 or less on the Rockwell "B" Scale	85 or less on the Rockwell "B" Scale	92 or less on the Rockwell "B" Scale
AFHL	•	•					•						•			
AFHLS	•		•						•			•				

- (1) Material properties – yield strength: 50,000 psi (345 MPa), tensile strength: 63,000 psi (434 MPa).
- (2) Part numbers for aluminum studs have no plating suffix.
- (3) "X" suffix studs may have pitch diameters and major diameters below 2A "Basic", per ANSI B1.1, Section 7, and B1.13M, Section 8 to allow for minimum of 0.0002" of plating.
- * For plated studs, Class 2A/6g, the maximum major and pitch diameter, after plating, may equal basic sizes and be gauged to Class 3A/4h. Per ANSI B1.1, Section 8, Table 3A and ANSI B1.13M, Section 8, paragraph 8.2.

INSTALLATION

For Types AFHL, AFHLS

Self-clinching studs are installed by placing them in punched or drilled holes in the sheet material and squeezing them into place with any standard press. All that is required is a flat or recessed punch and a plain anvil having a hole to clear the thread diameter so that force is applied between the top of the stud head and underside of the sheet material. The squeezing action forces the ribs of the stud into the sheet, displacing sheet material, causing it to fill the annular groove under the head of the stud.

The following information provides specifics with regard to stud installation.

UNIFIED (in ch)	Thread Code	Anvil Dimensions	
		A	C
	256	.110-.114	.087-.090
	440	.136-.140	.113-.116
	632	.162-.166	.139-.142
	832	.188-.192	.165-.168
	024 & 032	.216-.220	.191-.194
	0420	.295-.300	.250-.253
	0518	.334-.338	.3125-.3155
	0616	—	.375-.378

METRIC (mm)	Thread Code	Anvil Dimensions	
		A + 0.1	C + 0.08
	M2.5	3.1	2.53
	M3	3.6	3.03
	M3.5	4.1	3.53
	M4	4.6	4.03
	M5	5.6	5.03
	M6	6.6	6.03
	M8	8.6	8.03
	M10	—	10.03

Type AFHL/AFHLS Studs

The two sketches below indicate suggested tooling for applying installation forces. Note that for sheets .060" / 1.51 mm and thicker, the anvil requires only a straight thru hole to accommodate the stud. For sheets less than .060" / 1.51 mm, the hole requires a countersink with dimension A at the top to provide for metal flow around the shank of the stud.

Tooling for sheet thicknesses less than .060" / 1.51 mm.

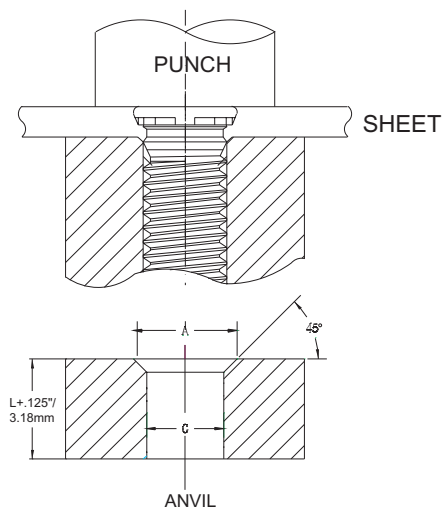

Tooling for sheet thicknesses .060" / 1.51 mm and greater.

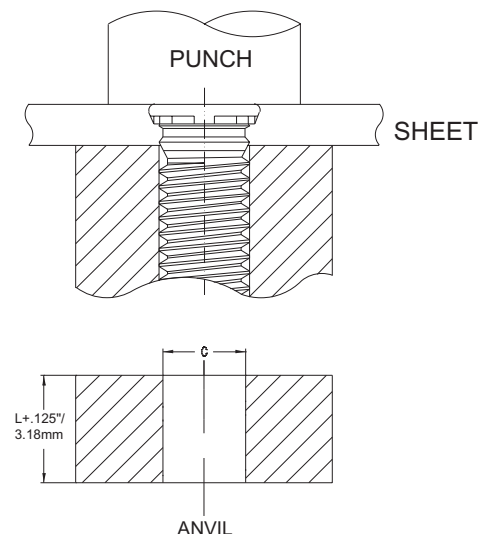

SELF-CLINCHING STUDS AND PINS



SELF-CLINCHING STUD SELECTOR GUIDE

Self-Clinching Stud Type	Application Requires:									
	Flush-head	High-strength	Sheet thickness as thin as .020" / 0.51mm	High electrical conductivity	Mounting into stainless steel sheets	Compatibility with aluminum anodizing	High corrosion resistance	Reduced centerline-to-edge distance	Unthreaded	Lead-in for assembly ease
AFHL	•							•		
AFHLS	•						•	•		

PERFORMANCE DATA (1)

Type AFHL and AFHLS Self-clinching Studs

UNIFIED (inch)	Thread Code	Max. Nut Tightening Torque (in. lbs.)	Type	Test Sheet Thickness and Material	Sheet Hardness HRB	Installation (lbs.)	Pushout (lbs.)	Torque-out (in. lbs.)	Pull Thru (lbs.)	Pull Thru Test Bushing Hole Size (in.)
	256		2.3	AFHL / AFHLS	.047" Aluminum	33	700	55	4	230
		2.3	AFHL / AFHLS	.045" Steel	54	1200	85	8	425	.106
440		4.0	AFHL / AFHLS	.047" Aluminum	33	1000	60	5	300	.132
		5.0	AFHL / AFHLS	.045" Steel	54	1200	105	11	580	.132
632		5.4	AFHL / AFHLS	.047" Aluminum	33	1000	65	6.5	325	.158
		9.0	AFHL / AFHLS	.045" Steel	54	1500	110	15	650	.158
832		6.9	AFHL / AFHLS	.047" Aluminum	33	1200	80	9	350	.184
		15.2	AFHL / AFHLS	.045" Steel	54	1500	125	18	740	.184
032		9.7	AFHL / AFHLS	.047" Aluminum	33	2500	115	18	395	.210
		19.4	AFHL / AFHLS	.045" Steel	54	4500	210	38	800	.210

METRIC (mm)	Thread Code	Max. Nut Tightening Torque (N•m)	Type	Test Sheet Thickness and Material	Sheet Hardness HRB	Installation (kN)	Pushout (N)	Torque-out (N•m)	Pull Thru (N)	Pull Thru Test Bushing Hole Size (mm)
	M2.5		0.41	AFHL / AFHLS	1.2 mm Aluminum	33	3.1	285	0.55	1200
		0.41	AFHL / AFHLS	1.1 mm Steel	54	5.3	450	1.1	2250	3
M3		0.46	AFHL / AFHLS	1.2 mm Aluminum	33	4.4	285	0.65	1300	3.5
		0.74	AFHL / AFHLS	1.1 mm Steel	54	5.3	475	1.25	2500	3.5
M3.5		0.58	AFHL / AFHLS	1.2 mm Aluminum	33	4.4	290	0.76	1400	4
		1.15	AFHL / AFHLS	1.1 mm Steel	54	6.6	500	1.75	2800	4
M4		0.75	AFHL / AFHLS	1.2 mm Aluminum	33	5.3	365	1.1	1550	4.5
		1.7	AFHL / AFHLS	1.1 mm Steel	54	6.6	550	2.1	3300	4.5
M5		1.11	AFHL / AFHLS	1.2 mm Aluminum	33	11.1	530	2.2	1850	5.5
		2.25	AFHL / AFHLS	1.1 mm Steel	54	20	1000	4.4	3750	5.5